

# HC977XF



## HC977XF Extended-Filter Triple-Band Helical Antenna + L-Band

**Frequency:** GNSS/QZSS-L1/L2/L5, GLONASS-G1/G2/G3, Galileo-E1/E5a/E5b, BeiDou-B1/B2/B2a, NavIC-L5  
**Coverage:** + L-Band correction services

### Overview

The patented HC977XF helical antenna is designed for precision positioning, covering the GPS/QZSS-L1/L2/L5, GLONASS-G1/G2/G3, Galileo-E1/E5a/E5b, BeiDou-B1/B2/B2a, and NavIC-L5 frequency bands, including the satellite-based augmentation system (SBAS) available in the region of operation [WAAS (North America), EGNOS (Europe), MSAS (Japan), or GAGAN (India)], as well as L-Band correction services.

Weighing only 42 g, the light and compact HC977XF features a precision-tuned helix element that provides excellent axial ratios and operates without the requirement of a ground plane, making it ideal for a wide variety of applications, including unmanned aerial vehicles (UAVs).

The HC977XF features an industry-leading low current, low-noise amplifier (LNA) that includes an integrated low-loss pre-filter. eXtended Filtering was added to the HC977 antenna to mitigate new radio frequency bands that interfere with GNSS signals. For example, new LTE bands have been activated, and their signal or harmonic frequencies can affect GNSS antennas and receivers. In North America, the planned Ligado service, which will broadcast in the frequency range of 1526 to 1536 MHz, can affect GNSS antennas that receive space-based L-band correction service signals (1539 - 1559 MHz). Similarly, new LTE signals in Europe [Band 32 (1452 - 1496 MHz)] and Japan [Bands 11 and 21 (1476 - 1511 MHz)] have also affected GNSS signals. Lastly, the Inmarsat satellite communication uplink (1626.5 - 1660.5 MHz), commonly used on maritime vessels, can also affect nearby GNSS antennas.

Field tests have confirmed that Tallysman's custom XF filtering mitigates the new (Europe and Japan) and existing LTE signals, enabling the XF antenna to produce clean and pure GNSS radio frequency data.

All Tallysman housed helical antenna elements are protected by a robust military-grade IP69K-compliant plastic enclosure. The enclosure's base provides two threaded inserts for secure attachment, as well as a rubber O-ring around the outer edge to seal the antenna base and its integrated male SMA connector.

Tallysman's helical family has passed a rigorous 30-hour vibration test procedure, consisting of five cycles of 2-hour tests per axis (x, y, z):

- Cycle 1: 1.05 Grms;
- Cycle 2: 1.20 Grms;
- Cycle 3: 1.35 Grms;
- Cycle 4: 3.67 Grms;
- Cycle 5: 3.67 Grms.

For mounting instructions, visit:

[https://www.tallysman.com/downloads/Helical\\_Mounting\\_Instruction.pdf](https://www.tallysman.com/downloads/Helical_Mounting_Instruction.pdf)



### Applications

- Autonomous unmanned aerial vehicles (UAVs)
- Precision GNSS positioning
- Precision land survey positioning
- Mission-critical GNSS timing
- Network timing and synchronization
- Sea and land container tracking
- Fleet management and asset tracking
- Marine and avionics systems
- Law enforcement and public safety

### Features

- Very low noise preamp (2.5 dB typ.)
- Axial ratio ( $\leq$  0.5 dB at zenith)
- LNA gain (28 dB typ. | 35 dB typ.)
- Low current (25 mA typ. | 31 mA typ.)
- ESD circuit protection (15 kV)
- Invariant performance from 2.2 to 16 VDC
- IP69K, REACH, and RoHS compliant

### Benefits

- Extremely light (42 g)
- Ideal for RTK and PPP surveying systems
- Excellent RH circular polarized signal reception
- Great multipath rejection
- Increased system accuracy
- Excellent signal-to-noise ratio
- Industrial temperature range
- Rugged design, ideal for harsh environments

**About Tallysman:** With global headquarters and manufacturing in Ottawa, Canada, Tallysman is a leading manufacturer of high-precision antennas and components for Global Navigation Satellite System (GNSS) applications. Tallysman's mission is to support the needs of a new generation of positioning systems by delivering unprecedented antenna precision at competitive prices. Learn more at [www.tallysman.com](http://www.tallysman.com)

Revision: 202203

**Contact us:**  
[info@tallysman.com](mailto:info@tallysman.com)  
T: +1 613 591-3131

# HC977XF Extended-Filter Triple-Band Helical Antenna + L-Band

**Frequency Coverage:** GNSS/QZSS-L1/L2/L5, GLONASS-G1/G2/G3, Galileo-E1/E5a/E5b, BeiDou-B1/B2/B2a, NavIC-L5  
+ L-Band correction services

## Antenna

**Technology** Triple-frequency, RHCP quadrifilar helix

		Gain	Axial Ratio
		dBic typ. at Zenith	dB at Zenith
<b>GNSS</b>			
GPS / QZSS	L1	2.5	≤ 0.5
	L2	2	≤ 0.5
	L5	1	≤ 0.5
GLONASS	G1	1.5	≤ 0.5
	G2	1.1	≤ 0.5
	G3	2.6	≤ 0.5
Galileo	E1	2.5	≤ 0.5
	E5A	1.1	≤ 0.5
	E5B	2.2	≤ 0.5
	E6	-	-
BeiDou	B1	2.5	≤ 0.5
	B2	2.7	≤ 0.5
	B2a	1	≤ 0.5
	B3	-	-
IRNSS / NavIC	L5	1	≤ 0.5
QZSS	L6	-	-
L-Band Services (1525 MHz - 1559 MHz)		1.5	≤ 0.5
<b>Satellite Communications</b>			
Iridium		-	-
Globalstar		-	-
<b>Other</b>			
Axial Ratio at 10°	-	Efficiency	-
PC Variation	± 3.0 mm (all freq.)	PCO	-

## Mechanicals

<b>Mechanical Size</b>	44.2 mm (dia.) x 62.4 mm (h.)
<b>Weight</b>	42 g
<b>Radome</b>	3x M2.5 screws
<b>Mount</b>	SMA (male)
<b>Available Connectors</b>	Radome and Base: EXL9330

## Environmental

<b>Operating Temperature</b>	-40 °C to + 85 °C
<b>Storage Temperature</b>	-50 °C to + 95 °C
<b>Vibration</b>	MIL-STD-810E - Test method 514.5
<b>Shock</b>	MIL-STD-810E - Test method 514.5
<b>Salt Fog</b>	-
<b>IP Rating</b>	IP69K
<b>Compliance</b>	IPC-A-610, FCC, RED / CE Mark, RoHS, REACH

## Warranty:

<b>Parts and Labour</b>	3-year standard warranty
-------------------------	--------------------------

## Low Noise Amplifier (LNA) - Measured at 3V and 25°C

Frequency Bandwidth		Out of Band Rejection
<b>Lower Band</b>	1164 - 1255 MHz	Pre-filter → LNA
<b>L-Band - Correction Services</b>	1164 - 1255 MHz	
<b>Upper Band</b>	1559 - 1606 MHz	≥ 65 dB @ ≤ 1500 MHz ≥ 45 dB @ ≤ 1525 MHz ≥ 05 dB @ ≤ 1536 MHz ≥ 30 dB @ ≥ 1626 MHz ≥ 65 dB @ ≥ 1650 MHz

<b>Architecture</b>	28 dB typ.   35 dB typ.
<b>Gain</b>	2.5 dB typ.
<b>Noise Figure</b>	< 1.5:1 typ.   1.8:1 max.
<b>VSWR</b>	2.2 to 16 VDC
<b>Supply Voltage Range</b>	25 mA typ. (28 dB)   31 mA typ. (35 dB)
<b>Supply Current</b>	15 kV air discharge
<b>ESD Circuit Protection</b>	13.3 dBm @ L1   13.1 dBm @ L2/L5
<b>P 1dB Output</b>	20 ns @ L1   18 ns @ L2   36 ns @ L5
<b>Group Delay</b>	20 ns @ L1   18 ns @ L2   36 ns @ L5

## Mechanical Diagram

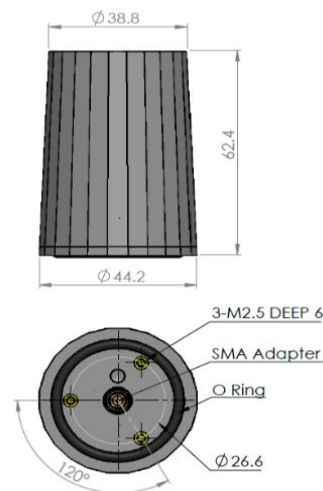

## Ordering Information

<b>Part Number</b>	<b>33-HC977XF-xx</b>
	where xx = gain (28 or 35 dB)

Please refer to our **Ordering Guide** to review available radomes and connectors at: <https://www.tallysman.com/resource/tallysman-ordering-guide/>