

HC843

HC843 Active Dual-Band GNSS + Passive Iridium Helical Antenna

Frequency Coverage: GNSS/QZSS-L1/L2, GLONASS-G1/G2, Galileo-E1, BeiDou-B1 + Passive Iridium

Overview

The patented dual-purpose (GNSS and Iridium signal reception) HC843 helical antenna is designed for precision positioning, covering the GPS/QZSS-L1/L2, GLONASS-G1/G2, Galileo-E1, and BeiDou-B1 frequency bands, including the satellite-based augmentation system (SBAS) available in the region of operation [WAAS (North America), EGNOS (Europe), MSAS (Japan), or GAGAN (India)]. The HC843 also passively supports communications over voice and data modems on the Iridium[®] frequency band (1616.0 - 1626.5 MHz).

The HC843 is switchable between the passive Iridium and the active GNSS antenna: an input voltage lower than 5.2 VDC engages the GNSS antenna, while an input voltage of 5.5 VDC and above invokes the passive Iridium antenna.

Weighing only 42 g, the light and compact HC843 features a precision-tuned helix element that provides excellent axial ratios and operates without the requirement of a ground plane, making it ideal for a wide variety of applications, including unmanned aerial vehicles (UAVs).

The HC843 features an industry-leading low current, low-noise amplifier (LNA) that includes an integrated low-loss pre-filter to prevent harmonic interference from high-amplitude signals, such as 700 MHz band LTE and other nearby in-Band cellular signals.

Tallysman's helical family has passed a rigorous 30-hour vibration test procedure, consisting of five cycles of 2-hour tests per axis (x, y, z):

- Cycle 1: 1.05 Grms;
- Cycle 2: 1.20 Grms;
- Cycle 3: 1.35 Grms;
- Cycle 4: 3.67 Grms;
- Cycle 5: 3.67 Grms.

All Tallysman housed helical antenna elements are protected by a robust military-grade IP69K-compliant plastic enclosure. The enclosure's base provides three threaded inserts for secure attachment, as well as a rubber O-ring around the outer edge to seal the antenna base and its integrated male SMA connector.

For mounting instructions, visit:

https://www.tallysman.com/downloads/Helical_Mounting_Instruction.pdf



Applications

- Iridium[®] voice and data applications
- Autonomous unmanned aerial vehicles (UAVs)
- Precision GNSS positioning
- Precision land survey positioning
- Mission-critical GNSS timing
- Network timing and synchronization
- Sea and land container tracking
- Fleet management and asset tracking
- Marine and avionics systems
- Law enforcement and public safety

Features

- Low noise preamp (3.0 dB typ.)
- Axial ratio (≤ 0.5 dB at zenith)
- LNA gain (25 dB typ. | 24 dB min.)
- Low current (GNSS: 23 mA typ. | Iridium: 3.6 mA typ.)
- ESD circuit protection (15 kV)
- Invariant performance from 2.5 to 16 VDC
- GNSS-mode: 2.5 to 5.0 VDC
- Iridium-mode: 5.5 to 16 VDC
- IP69K, REACH, and RoHS compliant

Benefits

- Extremely light (42 g)
- Ideal for RTK and PPP surveying systems
- Excellent RH circular polarized signal reception
- Great multipath rejection
- Increased system accuracy
- Excellent signal-to-noise ratio
- Industrial temperature range
- Rugged design, ideal for harsh environments

About Tallysman: With global headquarters and manufacturing in Ottawa, Canada, Tallysman is a leading manufacturer of high-precision antennas and components for Global Navigation Satellite System (GNSS) applications. Tallysman's mission is to support the needs of a new generation of positioning systems by delivering unprecedented antenna precision at competitive prices. Learn more at www.tallysman.com

Revision: 202212

Contact us:
info@tallysman.com
T: +1 613 591-3131

HC843 Active Dual-Band GNSS + Passive Iridium Helical Antenna

Frequency Coverage: GNSS/QZSS-L1/L2, GLONASS-G1/G2, Galileo-E1, BeiDou-B1 + Passive Iridium

Antenna			
Technology		Dual-frequency, RHCP quadrifilar helix	
		Gain	Axial Ratio
		dBic typ. at Zenith	dB at Zenith
GNSS			
GPS / QZSS	L1	2.2	≤ 0.5
	L2	2.4	≤ 0.5
	L5	-	-
GLONASS	G1	2.6	≤ 0.5
	G2	2.1	≤ 0.5
	G3	-	-
Galileo	E1	2.2	≤ 0.5
	E5A	-	-
	E5B	-	-
	E6	-	-
BeiDou	B1	2.2	≤ 0.5
	B2	-	-
	B2a	-	-
	B3	-	-
IRNSS / NavIC	L5	-	-
QZSS	L6	-	-
L-Band Services (1525 MHz - 1559 MHz)			
		-	-
Satellite Communications			
Iridium		2.5	≤ 0.5
Globalstar		-	-
Other			
Axial Ratio at 10°	-	Efficiency	-
PC Variation	± 3.0 mm (all freq.)	PCO	-

Mechanicals	
Mechanical Size	44.2 mm (dia.) x 62.4 mm (h.)
Weight	42 g
Radome	Radome and Base: EXL9330
Mount	3x M2.5 screws
Available Connectors	SMA (male)

Environmental	
Operating Temperature	-45 °C to +85 °C
Storage Temperature	-55 °C to +95 °C
Vibration	MIL-STD-810E - Test method 514.5
Shock	MIL-STD-810E - Test method 514.5
Salt Fog	-
IP Rating	IP69K
Compliance	IPC-A-610, FCC, RED / CE Mark, RoHS, REACH

Warranty:	
Parts and Labour	3-year standard warranty

Low Noise Amplifier (LNA) - Measured at 3V and 25°C

Frequency Bandwith		Out of Band Rejection
Lower Band	1217 - 1255 MHz	> 35 dB @ < 1100 MHz > 30 dB @ < 1200 MHz
L-Band - Correction Services	-	-
Upper Band	1559 - 1626.5 MHz	> 36 dB @ < 1400 MHz > 40 dB @ < 1500 MHz > 38 dB @ > 1625 MHz > 45 dB @ > 1700 MHz

Architecture	Pre-filter → LNA
Gain	25 dB typ. 24 dB min
Noise Figure	3.0 dB typ.
VSWR	< 1.5:1 typ. 2.0:1 max.
Supply Voltage Range	GNSS: 2.5 to 5.0 VDC Iridium: 5.5 to 16 VDC
Supply Current	GNSS: 23 mA typ. Iridium: 3.6 mA typ.
ESD Circuit Protection	15 kV air discharge
P 1dB Output	10 dBm @ L1
Group Delay	10 dBm @ L1

Mechanical Diagram

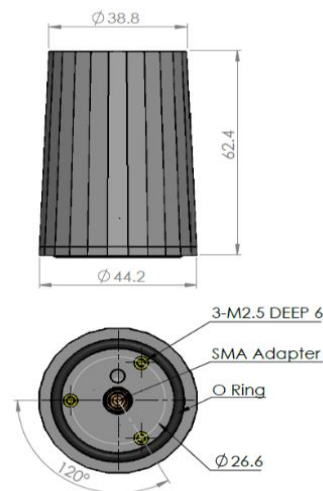

Ordering Information

Part Number **33-HC843**

Please refer to our **Ordering Guide** to review available radomes and connectors at: <https://www.tallysman.com/resource/tallysman-ordering-guide/>