

TW1010

GPS-L1 Antenna

Frequency Coverage: GPS L1

Overview

The TW1010 is low cost, high-gain, high performance, embedded GPS-L1 antenna, specially designed for OEM industrial, military, precision positioning and timing applications.

The TW1010 features a precisely tuned single-feed ceramic patch element. It has a two stage low-noise amplifier (LNA) with a mid-section SAW.

The TW1010 covers the GPS-L1 and SBAS (WAAS /EGNOS/MSAS) frequency band (1572.5 to 1578 MHz), and it offers great circular polarized signal reception, multipath rejection and out-of-band signal rejection. The TW1010 has a built-in 35 mm circular ground plane that can be augmented with host system ground surfaces. Patch elements are susceptible to detuning by the local environment.

Calian offers custom services to assist with integration of OEM modules into an end user solution.

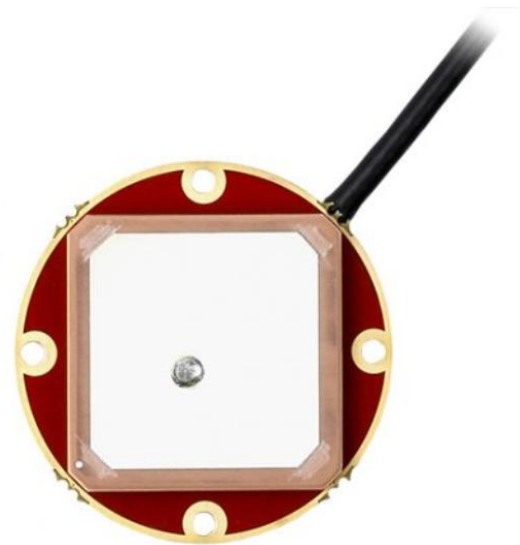

Applications

- High-accuracy & mission-critical global positioning
- Precision agriculture, mining, and construction
- Law enforcement and public safety
- Avionics
- Law enforcement and public safety
- Fleet management and asset tracking

Features

- Low noise figure, 1 dB typ.
- Great axial ratio, ≤ 4 dB at Zenith
- High-rejection SAW filter
- LNA gain (28 dB typ.)
- Low current (9 mA typ.)
- ESD circuit protection (15 kV)
- Wide Supply voltage: 2.5V to 16V

Benefits

- Low Profile: 7.7 mm
- Great multipath rejection
- Increase system accuracy
- Excellent signal-to-noise ratio
- Great out-of-band signal rejection
- Compact form factor
- RoHS compliant

About Calian: With global headquarters and manufacturing in Ottawa, Canada, Calian is a leading manufacturer of high-precision antennas and components for Global Navigation Satellite System (GNSS) applications. Calian's mission is to support the needs of a new generation of positioning systems by delivering unprecedented antenna precision at competitive prices. Learn more at www.calian.com

Contact us:
info@tallysman.com
T: +1 613 591-3131

GPS-L1 Antenna

Frequency Coverage: GPS L1

Antenna - Measured with a 100 mm ground plane

Technology Single-feed RHCP ceramic patch

		Gain	Axial Ratio
		dBic typ. at Zenith	dB at Zenith
GNSS			
GPS / QZSS	L1	4.0	≤ 4
	L2	-	-
	L5	-	-
GLONASS	G1	-	-
	G2	-	-
	G3	-	-
Galileo	E1	-	-
	E5A	-	-
	E5B	-	-
	E6	-	-
BeiDou	B1	-	-
	B2	-	-
	B2a	-	-
	B3	-	-
IRNSS / NavIC	L5	-	-
QZSS	L6	-	-
L-Band Services (1525 MHz - 1559 MHz)			
Satellite Communications			
Iridium		-	-
Globalstar		-	-
Other			
Axial Ratio at 10°	-	Efficiency	-
PC Variation	-		

Mechanicals

Size	35 mm (dia.) x 7.7 mm
Weight	13 g
Radome	-
Mount	Adhesive 4 · M2 screws
Available Connectors	Refer to Ordering Guide

Environmental

Operating Temperature	-40 °C to +85 °C
Storage Temperature	-55 °C to +95 °C
Vibration	MIL-STD-810D
Shock	Vertical axis: 50G, other axes: 30G
Salt Fog	-
IP Rating	-
Compliance	IPC-A-610, FCC, RED / CE Mark, RoHS, REACH

Warranty

Parts and Labour	1-year standard warranty
------------------	--------------------------

Low Noise Amplifier (LNA) - Measured at 3 V and 25°C

Upper Band	Lower Band
Frequency Bandwidth	
1575.42 MHz ± 10 MHz	-
Out-of-band Rejection	
> 35 dB @ < 1500 MHz > 25 dB @ < 1550 MHz > 35 dB @ > 1650 MHz	-

Architecture	Non pre-filtered
Gain	28 dB typ., 26 dB min.
Noise Figure	1 dB typ.
VSWR	< 1.5:1 typ., 1.8:1 max.
Supply Voltage Range	2.5 to 16 VDC nominal, up to 50mV p-p ripple
Supply Current	9 mA typ.
ESD Circuit Protection	15 kV air discharge
P 1dB Output	-
Group Delay	-
PCO	-

Mechanical Diagram

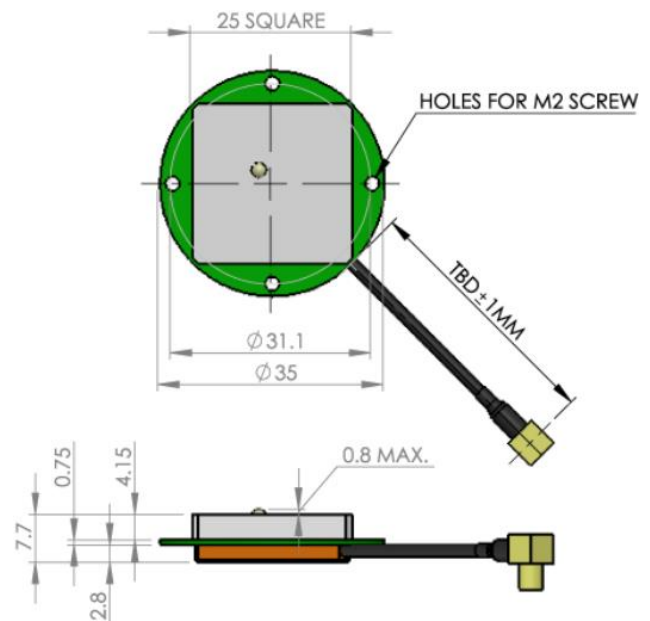

Ordering Information

Part Number 33-1010-xx-yyyy-zz

Where xx = connector type yyyy = cable length (in mm) and zz = reserved for Calian's use

Please refer to our **Ordering Guide** to review available radomes and connectors at: <https://www.tallysman.com/resource/tallysman-ordering-guide/>